California Subject Examinations for Teachers (CSET®)

CSET: Multiple Subjects Practice Test

Subtest II



Science; Mathematics

Copyright © 2017 Pearson Education, Inc. or its affiliate(s). All rights reserved.
Evaluation Systems, Pearson, P.O. Box 226, Amherst, MA 01004

California Subject Examinations for Teachers, CSET, and the CSET logo are trademarks of the
Commission on Teacher Credentialing and Pearson Education, Inc. or its affiliate(s).

Pearson and its logo are trademarks, in the U.S. and/or other countries, of Pearson Education, Inc. or its affiliate(s).

TABLE OF CONTENTS

Introduction and Test Directions **1**

Multiple-Choice Answer Sheet **2**

Multiple-Choice Questions..... **3**

Constructed-Response Directions and Evaluation Recommendations **29**

Constructed-Response Assignments and Response Sheets **30**

Results **38**

INTRODUCTION

This practice test is a full-length sample test consisting of 52 multiple-choice questions and four constructed-response assignments. An answer sheet for the multiple-choice questions, blank response sheets for the constructed-response assignments, and a Domain Results Worksheet for each domain are also included.

TEST DIRECTIONS

This practice test consists of two sections: (1) a multiple-choice question section and (2) a constructed-response assignment section. Each question in the **first section** of the practice test is a multiple-choice question with four answer choices. Read each question carefully and choose the **ONE** best answer. Record each answer on the answer sheet provided on page 2.

The **second section** of this practice test contains constructed-response assignments, which require written responses. Directions for the constructed-response assignments appear immediately before those assignments.

You may work on the multiple-choice questions and constructed-response assignments in any order that you choose. You may wish to monitor how long it takes you to complete the practice test. When taking the actual CSET: Multiple Subjects, you will have one five-hour test session in which to complete all three subtests. If you register to take just Subtest II, you will have one three-hour session in which to complete the subtest.

MULTIPLE-CHOICE ANSWER SHEET

Science

Question Number	Your Response
1	
2	
3	
4	
5	
6	
7	
8	
9	
10	
11	
12	
13	
14	
15	
16	
17	
18	
19	
20	
21	
22	
23	
24	
25	
26	

Mathematics

Question Number	Your Response
27	
28	
29	
30	
31	
32	
33	
34	
35	
36	
37	
38	
39	
40	
41	
42	
43	
44	
45	
46	
47	
48	
49	
50	
51	
52	

MULTIPLE-CHOICE QUESTIONS

1. Which of the following steps in making a cup of coffee involves a chemical change in matter?
- A. Whole-bean coffee is ground in a coffee grinder.
 - B. A burner on a propane stove is lighted to heat water.
 - C. Water in a kettle begins to boil.
 - D. Boiling water is poured through a filter containing ground coffee.

2. Use the section of the periodic table below to answer the question that follows.

6 C 12.01	7 N 14.01	8 O 16.00
14 Si 28.1	15 P 31.0	16 S 32.1
32 Ge 72.6	33 As 74.9	34 Se 79.0
50 Sn 118.7	51 Sb 121.8	52 Te 127.6
82 Pb 207.2	83 Bi 209.0	84 Po (210)

Which of the elements in the section of the periodic table shown above are likely to have the most similar chemical properties?

- A. Si and Ge
- B. C and O
- C. Sb and Te
- D. N and S

Multiple Subjects Practice Test: Subtest II

3. Which of the following liquids is the most acidic and will have the lowest pH?
- A. milk
 - B. household ammonia
 - C. distilled water
 - D. vinegar
4. Ultraviolet light and visible light are types of radiation that are part of the electromagnetic spectrum. Compared to visible light waves, ultraviolet waves:
- A. exhibit a longer wavelength.
 - B. have a higher frequency.
 - C. travel at a slower speed.
 - D. have a greater amplitude.
5. Which of the following is the best example of the refraction of light waves?
- A. Markings on flowers that are invisible in normal light can be seen in ultraviolet light.
 - B. Deep lakes appear to be blue or green in color.
 - C. Sunlight striking a black box will make the box warmer than the same light striking a white box.
 - D. Light passing through raindrops produces a rainbow.
6. Newton's third law of motion states that for every action there is an equal and opposite reaction. Which of the following is the best example of the application of this law?
- A. More fuel is needed to drive a truck ten miles when it is loaded than when it is unloaded.
 - B. An inflated balloon moves through the air when a jet of air leaves its neck as it deflates.
 - C. Less force is needed to pull a sled over ice than is needed to pull it over sand.
 - D. A passenger in a car continues moving forward when the car stops suddenly.
7. Which of the following examples best demonstrates the difference between thermal energy and temperature?
- A. A cup of water at 50°C contains less thermal energy than a bathtub full of water at 10°C .
 - B. The same amount of water loses heat faster if it is in a tall, narrow bottle than if it is in a short, wide bottle.
 - C. A dark-colored object gets warmer in the sun than a light-colored object.
 - D. A person feels cooler on a cold day when the wind is blowing.

8. A large round boulder is pushed from the top of a smooth steep hill and rolls to the bottom. Which of the following graphs shows the distance the boulder travels with respect to time as it rolls down the hill?

A.

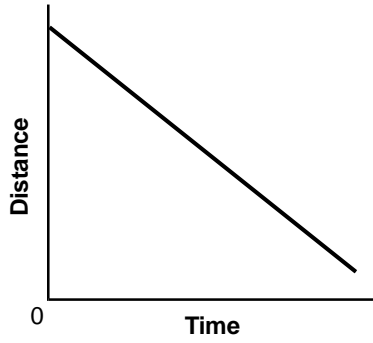

B.

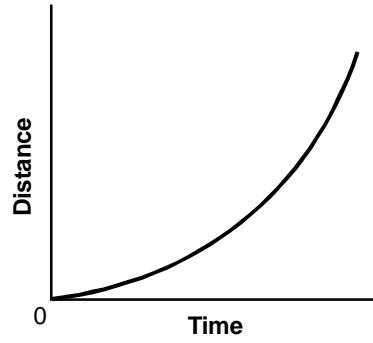

C.

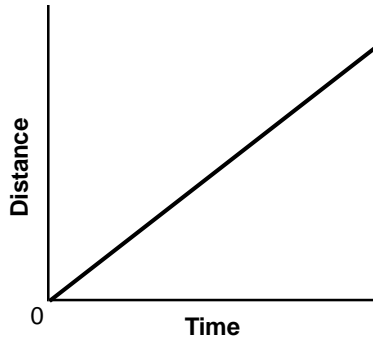

D.



9. The stems of a bunch of just-cut white flowers are immersed in a container of water to which blue dye has been added. After 24 hours, 2 tablespoons of salt are added to the water. Twenty-four hours later the flowers will most likely appear:
- A. wilted and light blue.
 - B. fresh and white.
 - C. wilted and white.
 - D. fresh and light blue.
10. Which of the following statements best explains how carbon plays a central role in the functioning of biological systems?
- A. Carbon actively transports nutrients and wastes across cell membranes.
 - B. Carbon insulates nerves because it has very low electrical conductivity.
 - C. Carbon combines with other elements to form a variety of useful compounds.
 - D. Carbon transports oxygen through the bloodstream to the cells of the body.
11. When a seed germinates, its roots will grow down and its shoots will grow up, even if the seed is planted upside down. This downward growth of roots and upward growth of shoots is due to the plant's response to:
- A. gravity.
 - B. light.
 - C. temperature.
 - D. moisture.
12. Organisms maintain stability in a changing environment by changing themselves. These changes can be detected over time and may occur at different rates. Which of the following examples illustrates an organism accommodating or adjusting to a change in its environment, rather than adapting to environmental changes?
- A. Rose plants grow thorns on their stems to protect themselves from predators.
 - B. Whales migrate seasonally to warmer waters to mate and give birth.
 - C. Blood vessels in a human body constrict to conserve heat during cold weather.
 - D. Glands in honeysuckle flowers secrete nectar to attract insects and birds as pollinators.

13. Certain species of acacia trees have long hollow thorns that house stinging ants. The ants feed on nectar produced by the tree and attack anything that touches the tree. The relationship between the ants and the acacias is an example of:

- A. mutualism.
- B. parasitism.
- C. commensalism.
- D. predation.

14. Use the information below to answer the question that follows.

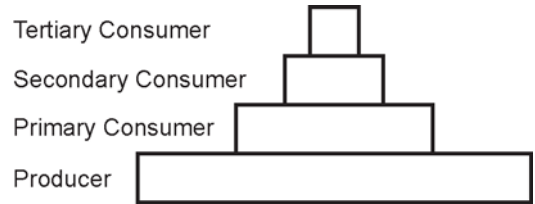

The diagram above is a generalized energy pyramid for a freshwater swamp and surrounding forest in a mild, temperate climate. The swamp is dominated by reeds and other swamp grasses, with various shrubs and trees on the higher ground. A large number of animal species, ranging in size from small insects to deer, are present in the swamp and forest.

The energy pyramid is narrower at the top than at the bottom because organisms at the higher levels:

- A. exploit a narrower range of environmental resources than the organisms at the lower levels.
- B. are larger and require less energy per unit of body mass than the organisms at the lower levels.
- C. have less energy available to them than organisms at the lower levels.
- D. are more efficient at producing energy from sunlight than the organisms at the lower levels.

15. Some species of aphids can reproduce asexually under certain conditions. Female aphids produce other female aphids without being fertilized by a male. This asexual reproduction may continue over many generations during the summer. In late summer or early fall, male aphids are produced and sexual reproduction resumes. Which of the following is most likely to be an advantage to a female aphid asexually reproducing during the summer?
- A. Competition for food increases in summer, and the aphid's offspring aid in defending resources.
 - B. Unstable environmental conditions in summer make it difficult for a female aphid to travel in order to find mates.
 - C. A female can replicate her genes very rapidly by producing large numbers of identical offspring when food is plentiful in summer.
 - D. A female aphid passes down favorable mutations to her offspring in the summer when temperatures are high.
16. In which of the following cases of cell division is the amount of genetic material halved?
- A. A bacterium undergoes fission to produce two cells.
 - B. Cells in the tail stump of a lizard divide and produce a new tail after the original tail is lost to a predator.
 - C. A cell in the testes of a male sparrow divides and produces four sperm.
 - D. An ovum in a female mouse divides shortly after being fertilized by a sperm from a male mouse.

17. Use the diagram below to answer the question that follows.

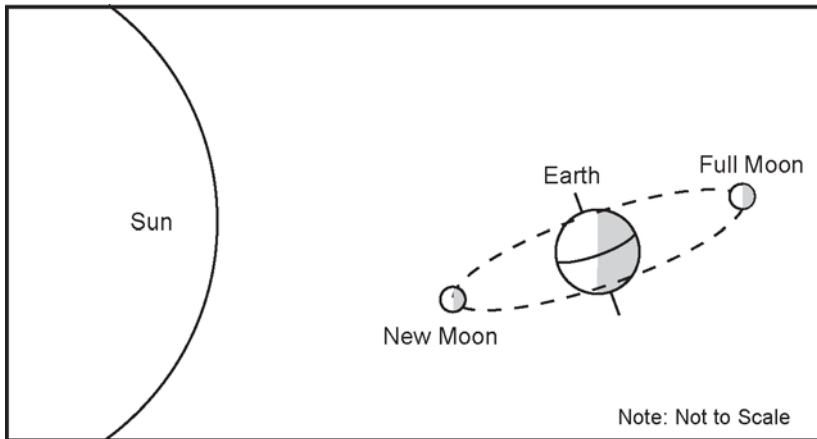

According to the diagram above, which of the following statements about the full moon is true?

- A. A lunar eclipse is visible somewhere on Earth whenever there is a full moon.
- B. The full moon is never in the sky at the same time as the sun.
- C. The moon always appears full somewhere on Earth.
- D. A full moon occurs whenever the moon is closest to Earth.

18. The shape of the Milky Way galaxy is best described as:
- A. a flat central disk with rotating spiral arms.
 - B. a spherical cloud of uniformly distributed matter.
 - C. a long, thin ribbon with ragged edges.
 - D. an irregular cluster with multiple concentrations of matter.
19. Which of the following best describes the structure of Earth?
- A. a thick oceanic and continental crust stretched over a solid mantle, with a liquid outer and a solid inner core
 - B. a thin oceanic and continental crust stretched over a solid mantle, with a solid outer and a liquid inner core
 - C. a thick oceanic and continental crust covering a liquid mantle that overlies a solid outer core and a liquid inner core
 - D. a thin oceanic and continental crust covering a liquid mantle overlies a liquid outer core and a solid inner core
20. During the Loma Prieta Earthquake of 1989, homes located nearest to San Francisco Bay generally sustained worse damage than similar homes further from the bay. The severity of the damage sustained by homes nearest to the bay is most likely due to the:
- A. presence of active faults that roughly parallel the shoreline.
 - B. intensity of secondary shaking near the shore from oscillating waves in the bay.
 - C. existence of sediments and fill near the shoreline.
 - D. rate at which earthquake waves accelerate as they pass through water.

21. Use the passage below to answer the question that follows.

Weather satellites, which provide information about areas of Earth not easily accessed by other technologies, may be either geostationary or polar orbiting. Geostationary satellites orbit in a fixed position near Earth's equator and provide wide-ranging data on Earth's atmosphere. Polar-orbiting satellites orbit at a lower altitude than geostationary satellites. They transmit higher-resolution images than geostationary satellites and provide data about meteorologic conditions at northern and southern latitudes.

Information provided by the satellites described in the passage is most likely to be used to monitor which of the following phenomena?

- A. wind shear
 - B. hurricanes
 - C. high levels of atmospheric ozone
 - D. development of areas of dense coastal fog
22. A scientist would use a barometer in order to compare which of the following conditions between two localities?
- A. wind speed
 - B. humidity
 - C. temperature
 - D. air pressure

23. Summer days in parts of California are occasionally interrupted by afternoon thunderstorms. Which of the following statements best describes the typical conditions that lead to these summer thunderstorms?
- A. High winds lift large quantities of dust into the air, providing particles around which water can condense into thunderheads.
 - B. Fast-moving winds in the upper atmosphere mix warm and cold air, creating turbulence and causing powerful updrafts and downdrafts.
 - C. A cold front moving through the area forces warm air up, causing condensation of water and the formation of thunderheads.
 - D. Humid conditions in a fast-moving warm front increase the electrical conductivity of the air, promoting lightning discharge.
24. As a river flows down a mountain to a plain, sediments are deposited in the following order: gravel first, then sand, then silt, and finally clay particles. Which of the following characteristics of the river is primarily responsible for this pattern of sediment deposition?
- A. the temperature
 - B. the velocity
 - C. the turbidity
 - D. the pH

25. Use the map below to answer the question that follows.

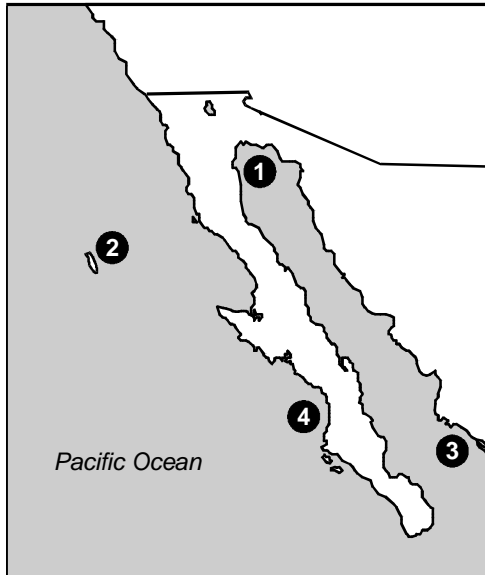

Which point on the map above would be likely to experience the greatest daily difference between high and low tides?

- A. Point 1
- B. Point 2
- C. Point 3
- D. Point 4

26. Certain lakes in arid environments, such as the Great Salt Lake in Utah and the Dead Sea in Israel, are extremely saline. Other lakes in similarly arid environments contain freshwater, rather than salt water. Which of the following is the most accurate explanation for the high salinity of saltwater lakes?

- A. Saltwater lakes are fed by underground hot springs that contain very high levels of dissolved mineral salts.
- B. Rivers that flow into saltwater lakes drain sparsely vegetated and easily eroded rock and soil that contain large quantities of mineral salts.
- C. Water does not drain out of saltwater lakes and is removed primarily by evaporation, which leaves salt behind.
- D. Saltwater lakes are deep and cold, and cold water is able to hold a greater quantity of salt in solution than warm water.

27. If the number 360 is written as a product of its prime factors in the form a^3b^2c , what is the numerical value of $a + b + c$?
- A. 10
 - B. 16
 - C. 17
 - D. 22

28. Use the diagram below to answer the question that follows.

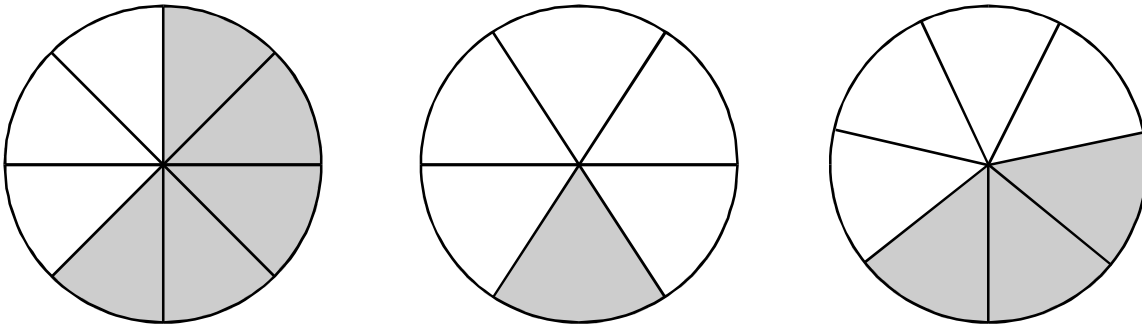

What is the sum of the shaded areas in the three circles above if each circle represents one unit?

- A. $1 \frac{9}{21}$
- B. $1 \frac{15}{42}$
- C. $1 \frac{37}{168}$
- D. $1 \frac{205}{336}$

29. Use the problem below to answer the question that follows.

For a bake sale, Marianne has baked p chocolate chip cookies and Jeffrey has baked q peanut butter cookies. They want to package their cookies separately so that each bag has the same number of cookies. How many cookies could they put in each bag?

Which of the following methods could be used to find all the solutions to this problem?

- A. Find the divisors of $p + q$.
 - B. Find the common factors of p and q .
 - C. Find the prime factors of $p \cdot q$.
 - D. Find the common multiples of p and q .
30. What value does the 2 represent in the number 2.1×10^{-3} ?

- A. $\frac{2}{10,000}$
- B. $\frac{2}{1000}$
- C. $\frac{2}{100}$
- D. $\frac{2}{10}$

31. Use the number line below to answer the question that follows.

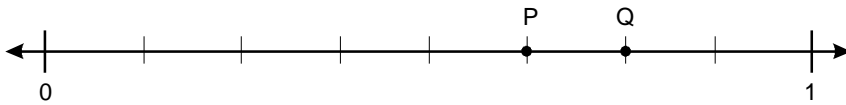

Which of the following numbers can be represented on the number line between points P and Q ?

- A. $\frac{17}{37}$
- B. $\frac{26}{43}$
- C. $\frac{39}{59}$
- D. $\frac{57}{71}$
32. In a town with a population of 4800 people, 8% of the population is evenly distributed in grades 1–6. Approximately how many students are in grade 4?
- A. 55
- B. 64
- C. 77
- D. 96

33. Use the numbers below to answer the question that follows.

212
206
246
238
231
216
224

To estimate the sum of the numbers given above, Riley first rounds each number to the nearest ten and then adds the rounded values. By how much will Riley's estimate differ from the actual sum?

- A. 3
B. 7
C. 33
D. 73
34. Which of the following illustrates the operation $1\frac{1}{2} \div \frac{1}{4}$?
- A. Sean has $1\frac{1}{2}$ pounds of popcorn. He wants to divide it equally into 4 bags. How many pounds should he put into each bag?
- B. A trip to the beach is usually a $1\frac{1}{2}$ -hour drive. Repairs to the freeway have increased the travel time by $\frac{1}{4}$. How long will the trip take?
- C. Maria has $1\frac{1}{2}$ yards of rope. She wants to divide it into $\frac{1}{4}$ -yard lengths. How many pieces of rope will she have?
- D. The perimeter of a rectangular field is $1\frac{1}{2}$ miles. The field is $\frac{1}{4}$ mile wide. How long is the field?

35. Pat is baking a cake. The recipe calls for $2\frac{1}{4}$ cups of flour per $\frac{1}{2}$ pound of butter. If Pat uses 3 cups of flour, how much butter should be used to keep the proportion of ingredients equal?

A. $\frac{1}{6}$ pound

B. $\frac{1}{4}$ pound

C. $\frac{3}{8}$ pound

D. $\frac{2}{3}$ pound

36. The problem below shows steps in finding the product of two two-digit numbers using this standard multiplication algorithm. The missing digits in the problem are represented by the symbol \square .

$$\begin{array}{r}
 \square 9 \\
 \times \quad 36 \\
 \hline
 29\square \\
 + \square 4\square\square \\
 \hline
 \square\square\square\square
 \end{array}$$

What is the hundreds digit in the product of the two numbers?

A. 1

B. 4

C. 6

D. 7

37. Use the table below to answer the question that follows.

Radius	Area
0.0	0
1.0	3.14
2.0	12.57
3.0	28.31
4.0	50.29

The table gives the area of several circles of different radii. Which of the following graphs best represents the data in the table?

A.

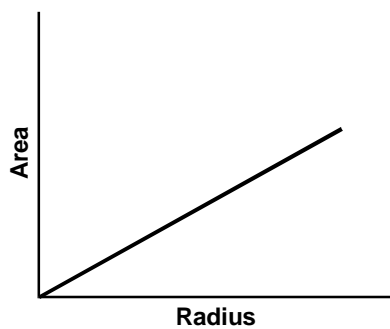

B.

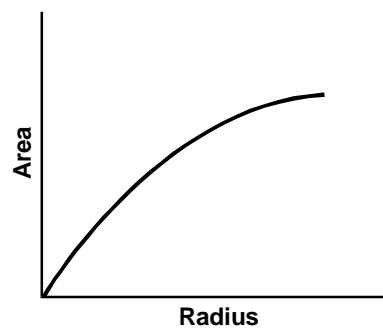

C.

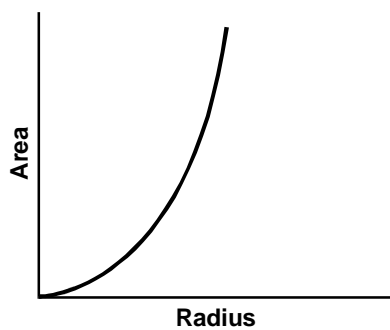

D.

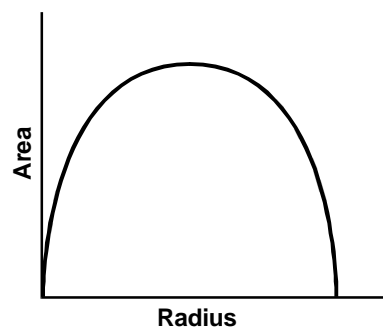

38. Grapefruits in a supermarket display are stacked in the shape of a pyramid. Each layer of the stack is square. The bottom layer is a square with 5 grapefruits on each side. The side of each successive layer is made shorter by one grapefruit. What is the total number of grapefruits that can be stacked?
- A. 15
 B. 35
 C. 54
 D. 55

39. Use the graph below to answer the question that follows.

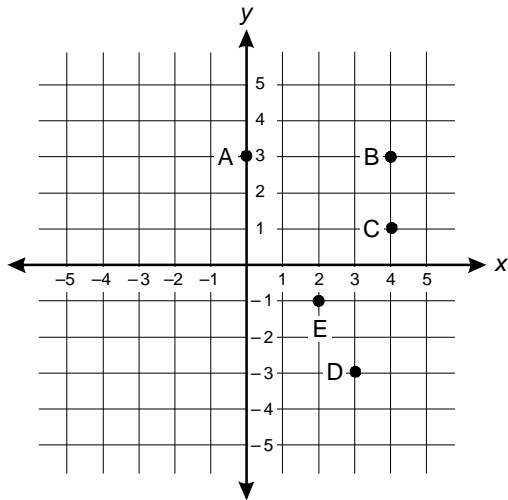

Point E is on a line with a slope of 2 in the x - y plane. Which of the following points is also on the line?

- A. A
 B. B
 C. C
 D. D

40. A repair person charges a \$30 fixed charge plus \$45 per hour for time spent working. What is the total bill for a job that requires n hours of work?

- A. $(\$30 + \$45)n$
- B. $\$15n + \30
- C. $\$30n + \45
- D. $\$45n + \30

41. Use the equation below to answer the question that follows.

$$3n + 2(n - 4) = n + 15$$

Which of the following equations could occur as a step in solving the equation above for n ?

- A. $4n = 19$
- B. $4n = 7$
- C. $4n = 23$
- D. $6n = 7$

42. Use the diagram below to answer the question that follows.

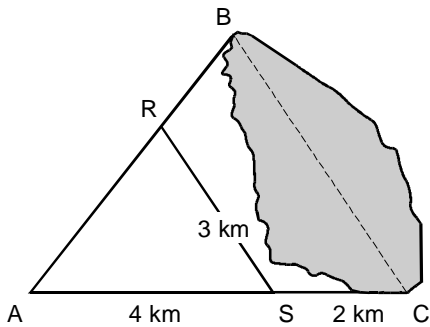

Note: not drawn to scale

To find the length of a lake, surveyors measure the distances shown such that $\triangle ABC$ and $\triangle ARS$ are similar. If $RS = 3$ km, $AS = 4$ km, and $SC = 2$ km, what is BC , the length of the lake?

- A. 4.5 km
 - B. 5 km
 - C. 6 km
 - D. 8 km
43. Triangle ABC is isosceles. Angle B has a measure of 120° . What is the measure of angle A ?
- A. 30°
 - B. 45°
 - C. 60°
 - D. 120°

44. Use the diagram below to answer the question that follows.

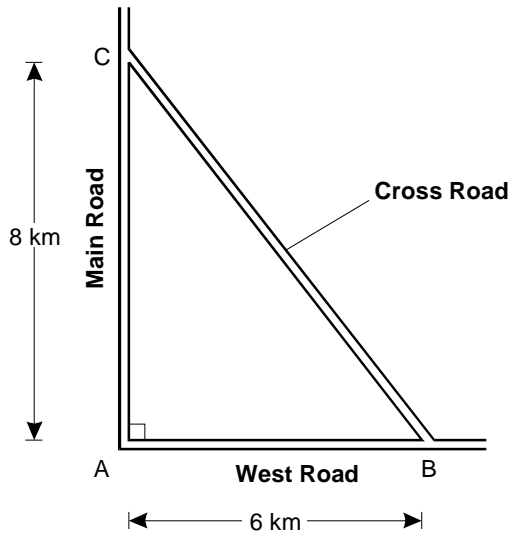

Main Road and West Road are perpendicular and intersect at point A. Cross Road intersects Main Road 8 km from point A and intersects West Road 6 km from point A. What is CB , the length of Cross Road?

- A. $\sqrt{28}$ km
- B. 10 km
- C. 14 km
- D. 28 km

45. Use the diagram below to answer the question that follows.

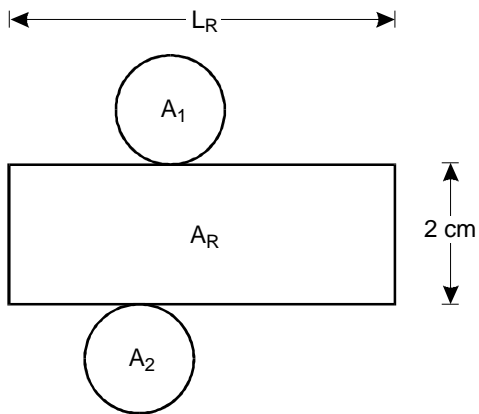

The figure above is rolled up and folded to make a cylinder of volume 10 cm^3 . Which of the following statements about the figure must be true?

- A. The area of the rectangular section, A_R , is 10 cm^2 .
- B. The length of the rectangle, L_R , is 5 cm^2 .
- C. The area of each circular section, A_1 and A_2 , is 5 cm^2 .
- D. The sum of the areas of the circular sections, $A_1 + A_2$, equals 5 cm^2 .

46. Use the diagram below to answer the question that follows.

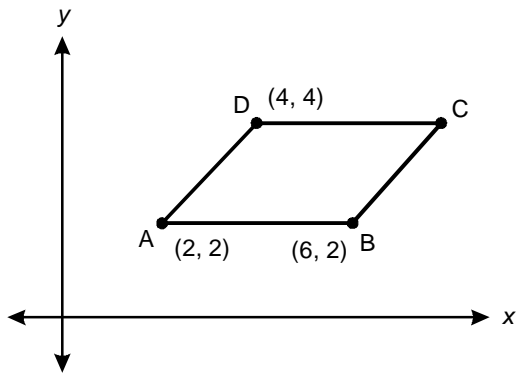

Given that figure $ABCD$ is a parallelogram, what are the coordinates of point C ?

- A. (4, 8)
- B. (6, 4)
- C. (8, 4)
- D. (12, 4)

47. Use the diagram below to answer the question that follows.

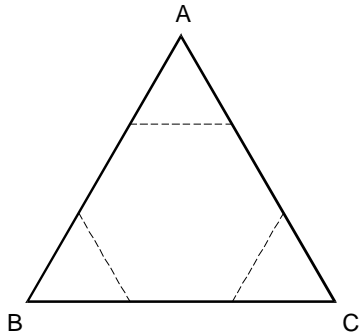

A regular hexagon is made from equilateral triangle ABC by cutting along the dotted lines and removing the three smaller triangles. If triangle ABC has a perimeter of 18, what is the perimeter of the hexagon?

- A. $6\sqrt{3}$
- B. 9
- C. 12
- D. 15

48. The scale on a map is 1 inch = 15 miles. On the same map, the distance between Belmont and Smithville is 13 inches. Which of the following is the best estimate of how long it will take to drive from Belmont to Smithville at an average speed of 60 miles per hour?
- A. 2 hours 8 minutes
 - B. 2 hours 14 minutes
 - C. 3 hours 15 minutes
 - D. 4 hours 0 minutes
49. In some countries, area is measured in *pings*. If the area of a rectangular piece of land that measures 22 feet \times 27 feet is 33 pings, how many square feet is equal to one ping?
- A. 6
 - B. 18
 - C. 26.9
 - D. 40.5

50. Use the table below to answer the question that follows.

Jan.	Feb.	Mar.	Apr.	May	June	July	Aug.	Sept.	Oct.	Nov.	Dec.
28°	29°	38°	44°	58°	73°	78°	77°	72°	63°	47°	35°

The table above gives the mean temperatures for each month of the year. What is the range in mean temperatures during this year?

- A. 50°
- B. 52.5°
- C. 53.0°
- D. 53.5°
51. The range of hourly wages for 15 employees of a small company starts at \$7.50 and ends at \$21.40. If only one worker receives the median wage of \$8.90, how many workers receive a higher hourly wage?
- A. 5
- B. 6
- C. 7
- D. 8

52. Each of the numbers from 4 to 24 inclusive is written on a separate piece of paper and placed in a bag. If one of these pieces of paper is randomly selected from the bag, what is the probability that the number on it will be a prime number?

A. $\frac{2}{7}$

B. $\frac{3}{10}$

C. $\frac{1}{3}$

D. $\frac{7}{20}$

CONSTRUCTED-RESPONSE DIRECTIONS AND EVALUATION RECOMMENDATIONS

Prepare a written response of approximately 100–200 words for each constructed-response assignment. Read each assignment carefully before you begin to write. Think about how you will organize what you plan to write.

Scoring of responses to CSET: Multiple Subjects constructed-response assignments is based on the following criteria.

- **PURPOSE:** the extent to which the response addresses the constructed-response assignment's charge in relation to relevant CSET subject matter requirements
- **SUBJECT MATTER KNOWLEDGE:** the application of accurate subject matter knowledge as described in the relevant CSET subject matter requirements
- **SUPPORT:** the appropriateness and quality of the supporting evidence in relation to relevant CSET subject matter requirements

The assignments are intended to assess subject matter knowledge, not writing ability. Your responses, however, must be communicated clearly enough to permit a valid judgment of your knowledge and skills. Your responses should be written for an audience of educators in the field.

You may wish to ask a mentor, advisor, or teacher to help evaluate your responses to the constructed-response assignments. Sample responses are provided for these assignments in the CSET: Multiple Subjects Test Guide (available at www.ctcexams.nesinc.com). You may wish to review these sample responses and/or refer to them when evaluating your practice test responses.

CONSTRUCTED-RESPONSE ASSIGNMENT #1

Complete the exercise that follows.

A butterfly collector is studying a species of butterfly that has expanded its range into a new area over the last 30 years. The butterflies in the new area feed on a species of flower that has a deeper throat than the flowers exploited by the butterfly species in its original range. The average length of the proboscis that is used to suck nectar from flowers is also greater in butterflies that inhabit the new area. The collector hypothesizes that individual butterflies that moved into the area and exploited the new flower grew longer proboscises during their lifetimes in order to reach the nectar. The gene for the longer proboscis was then inherited by the offspring of these original butterflies.

Using your knowledge of evolutionary theory and the underlying causes of evolution:

- describe the misconception underlying the collector's explanation for the increased proboscis length observed in butterflies inhabiting the new area;
- provide an alternative explanation that is consistent with accepted evolutionary theory for the change in proboscis length in butterflies inhabiting the new area; and
- provide one additional example of a type of environmental pressure that can lead to differences in physical characteristics within a species over time.

CONSTRUCTED-RESPONSE ASSIGNMENT #2

Use the diagram below to complete the exercise that follows.

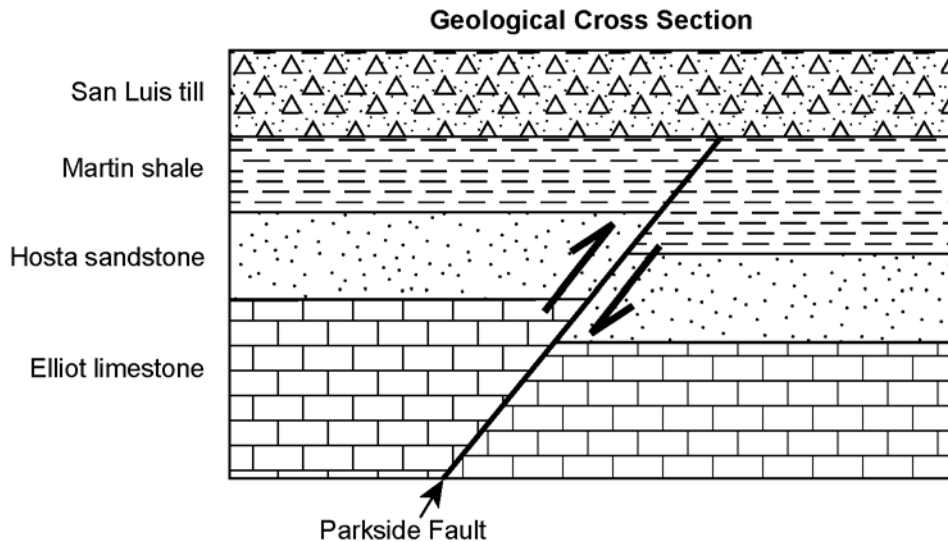

The diagram represents a geologic section through a sequence of layers of sedimentary rock. In this sequence, the following events, which are listed in random order, have occurred.

- deposition of the Elliot limestone
- Parkside fault
- deposition of the Martin shale
- deposition of the San Luis till
- erosion between the Martin shale and the San Luis till
- deposition of the Hosta sandstone

Using your knowledge of geology:

- list the correct order in which the events occurred, from longest ago to most recent;
- explain how you determined the order of the events; and
- identify one piece of evidence that supports the conclusion that erosion has occurred between the Martin shale and the San Luis till.

CONSTRUCTED-RESPONSE ASSIGNMENT #3

Use the diagram and the information below to complete the exercise that follows.

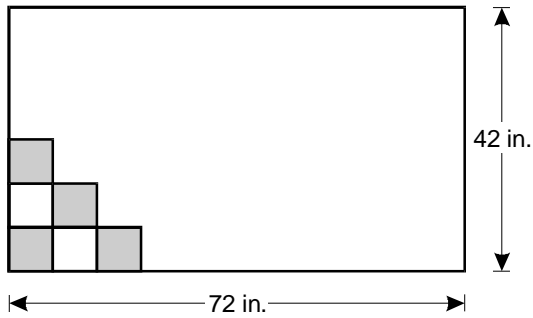

An artist is planning to construct a rectangular wall design from square tiles. The wall design is to be 72 inches long and 42 inches wide. All the square tiles must be the same size, and the length of the sides of the tiles must be a whole number.

Using your knowledge of number theory and geometry:

- find three different sizes of square tiles that could be used to completely fill the rectangular space, with no tiles overhanging the border; and
- determine the smallest number of square tiles that could be used to fill the rectangular space.

CONSTRUCTED-RESPONSE ASSIGNMENT #4

Complete the exercise that follows.

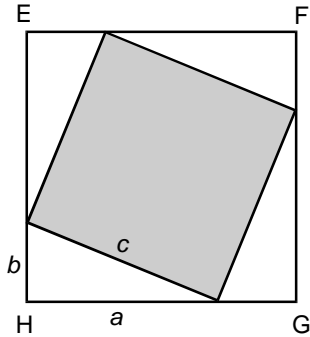

Four congruent triangles, each having legs of length a and b and hypotenuse of length c , are arranged as in the diagram above to produce square $EFGH$.

Using your knowledge of algebra and geometry:

- write an expression for the area of square $EFGH$ in terms of the length of its sides;
- write an expression for the area of square $EFGH$ in terms of the area of its component parts (i.e., four triangles and a square); and
- set these two expressions equal and show that this leads to a proof of the Pythagorean theorem.

CONSTRUCTED-RESPONSE SHEET—ASSIGNMENT #4

Scoring of responses to CSET: Multiple Subjects constructed-response assignments is based on the following criteria.

- **PURPOSE:** the extent to which the response addresses the constructed-response assignment's charge in relation to relevant CSET subject matter requirements
- **SUBJECT MATTER KNOWLEDGE:** the application of accurate subject matter knowledge as described in the relevant CSET subject matter requirements
- **SUPPORT:** the appropriateness and quality of the supporting evidence in relation to relevant CSET subject matter requirements

The assignments are intended to assess subject matter knowledge, not writing ability. Your responses, however, must be communicated clearly enough to permit a valid judgment of your knowledge and skills. Your responses should be written for an audience of educators in the field.

RESULTS

Using the Domain Results Worksheets

Domain Results Worksheets are provided to assist you in evaluating your multiple-choice responses. Each worksheet contains four columns. The first column indicates the multiple-choice question number and the second column indicates the correct response. The third and fourth columns are for your use in calculating the number of multiple-choice questions you answered correctly. Indicate whether you answered the question correctly or incorrectly.

Interpreting Your Results

The practice test provides valuable information regarding your preparedness on the domains tested by CSET: Multiple Subjects. It is not appropriate to try to use this practice test to predict how you might score on an official CSET: Multiple Subjects test.

If you answered correctly all of the questions associated with a given domain, you may choose to review only briefly the content of that domain as you prepare for the test. If you answered incorrectly all or many items associated with a domain, you may choose to allocate additional preparation time to study content in that domain. For domains on which you perform poorly, you may also wish to identify other resources for preparing for the test (e.g., assistance from a mentor, participation in a study group).

You may wish to ask a mentor, advisor, or teacher to help evaluate your responses to the constructed-response assignments. Sample responses are provided for these assignments in the CSET: Multiple Subjects Test Guide (available at www.ctcexams.nesinc.com). You may wish to review these sample responses and/or refer to them when evaluating your practice test responses.

Subtest II: Domain Results Worksheet**Science**

Question Number	Correct Response	Your Response	
		Correct?	Incorrect?
1	B		
2	A		
3	D		
4	B		
5	D		
6	B		
7	A		
8	B		
9	A		
10	C		
11	A		
12	C		
13	A		
14	C		
15	C		
16	C		
17	B		
18	A		
19	D		
20	C		
21	B		
22	D		
23	C		
24	B		
25	A		
26	C		

Count the number of multiple-choice questions you answered correctly:

_____ of 26 multiple-choice questions

Subtest II: Domain Results Worksheet

Mathematics

Question Number	Correct Response	Your Response	
		Correct?	Incorrect?
27	A		
28	C		
29	B		
30	B		
31	C		
32	B		
33	B		
34	C		
35	D		
36	D		
37	C		
38	D		
39	B		
40	D		
41	C		
42	A		
43	A		
44	B		
45	C		
46	C		
47	C		
48	C		
49	B		
50	A		
51	C		
52	C		

Count the number of multiple-choice questions you answered correctly:

_____ of 26 multiple-choice questions

Developed and Produced by



Pearson

Evaluation Systems

Pearson

P.O. Box 340813

Sacramento, CA 95834-0813